

8. Laminated Timber Arches

ARCHES

Description

The arch form has long been recognised as providing the most economical support structure. With the natural suppleness of timber and the techniques of glue lamination, Glulam arches are a low cost, highly efficient structural form. Glulam radial arches are well suited to achieve large, unobstructed, clear span enclosures, and can be used for a variety of buildings - Aircraft hangars, Sports stadiums, Display buildings.

They may be buttressed or tied, according to site conditions and building use. In the buttress arch, horizontal and vertical reactions are taken through concrete abutments.

Parabolic and Elliptical Arches can also be successfully achieved using the same principles.

FEATURES

Economy - Design efficiencies with the arch form allows minimum sized Glulam members to span large distances. Up to date production methods and experienced manufacturing techniques make McIntosh Glulam Beams economically attractive. Pre cut and pre finished, these structural members add to the aesthetics of your project.

Strength - Glulam beams maximise timber's strength by the use of selected seasoned material and the confining of knots to one lamination.

Stability - Multiple laminations with variety of grain, strong glue lines and seasoned timber make Glulam one of the most stable structural members.

Ease of Installation - Light, dry, timber beams arrive on site pre-fitted as arranged, ready for speedy installation. Glulam members are confidently handled by carpenters and sub contractors - they require no specialist erection techniques.

Pairs of half arches with purlins fixed in between are able to be assembled on the ground and lifted into place saving significant installation time.

Low Maintenance - Timber is naturally resistant to attack by corrosive atmospheres. Appropriate timber treatment avoids deterioration. Glulam members arrive sealed or stained. They require minimal long term maintenance.

Renewable Resource - Glulam utilizes New Zealand's most prolific, renewable resource. It requires less energy consumption and cost to produce Glulam beams than any other structural material. Glulam enables the best utilization of available timber supply by careful grading selection.

Shock Resistance - Glulam's resilience permits it to absorb seismic and wind shocks that would cause failure in other materials. Wood has excellent thermal, acoustic and electrical insulating qualities.

Fire Resistance - Glulam has a proven fire resistance. Char forming on the outer perimeter of the members prevents continuous combustion. Under fire conditions the Glulam member maintains its strength and does not fail. The allowed charring rate in NZ 3603 is 0.65mm per minute. Fire rating calculations should be done by a Structural Engineer.



Laminated Timber Arches

Table: Minimum Radius of Curvature

Net thickness of laminations	Member with constant curvature	Member with tangent ends
Thickness (mm)	Radii (mm)	Radii (mm)
10	1400	1200
13	2200	1800
16	3000	2300
19	3800	2800
45	12000	9700

SPECIFICATION

Timber - Standard Species. Radiata Pine surface treated, treated to H3 or Douglas Fir, Timber is graded to conform to NZS 3603 Table 2.2 .

Adhesives - Interior use - Melamine Fortified Urea. Exterior or wet conditions of use - Resorcinol or Phenol Resorcinol.

Appearance - Utility - planer finish - some lower surface permitted - suitable for industrial or concealed application.

Standard - exposed surfaces filled and sanded, suitable for all visual members.

Dimensions - Notching or cutting and drilling especially to edges and surfaces will reduce the design strength. Advice should be sought before cutting into beams.

Quality Control

McIntosh Timber Laminates are licensed manufacturers under AS/NZS 1328 Licence No. 2061. We also hold Licence No. 2354 under finger jointing code AS/NZS 1491. Regular in-factory quality control is carried out in conformance with these standards and also as required by AITC, BS and AS standards are achieved.

MCINTOSH TIMBER LAMINATES SERVICE

1. Free cost estimates on all types of Glulam.
2. Experienced advice on suitability of Glulam design options, sizing and connections to meet clients particular need.
3. Full engineering design and drawing facilities can be provided if required.
4. Complete building packages including design, manufacture, supply of all connections and components, and installation supervision is available.
5. Close liaison and client satisfaction are high priorities in McIntosh Timber Laminates personal service.

Table - Indicative Sizes for Elliptical Arches

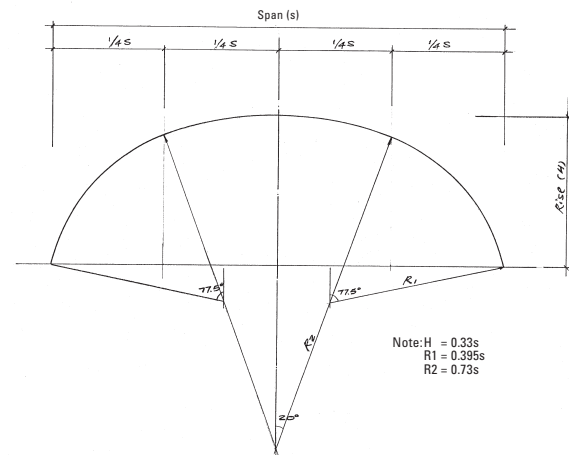

Span (m)	Spacing (m)	Rise (m)	Lamination (mm)	Light Roof & Ceiling	
				LL=0.25 k Pa	LL=0.25 k Pa
10	4	3.3	19	266 x 65	247 x 65
	6	3.3	19	266 x 65	247 x 65
12.5	4	4.1	19	266 x 65	247 x 65
	6	4.1	19	323 x 65	304 x 65
15	4	5.0	19	304 x 65	304 x 65
	6	5.0	19	323 x 90	304 x 90
17.5	4	5.8	19	304 x 90	304 x 90
	6	5.8	19	380 x 90	361 x 90
20	4	6.6	19	342 x 90	323 x 90
	6	6.6	19	437 x 90	418 x 90
	8	6.6	19	494 x 90	475 x 90
22.5	4	7.4	19	399 x 90	380 x 90
	6	7.4	19	494 x 90	475 x 90
	8.0	7.4	19	551 x 90	532 x 90
25	4	8.3	19	437 x 90	418 x 90
	6	8.3	19	532 x 90	513 x 90
	8	8.3	19	551 x 115	532 x 115
27.5	4	9.1	19	513 x 90	494 x 90
	6	9.1	19	513 x 115	494 x 115
	8	9.1	19	627 x 115	608 x 115
30	4	10.0	19	455 x 115	513 x 90
	6	10.0	19	570 x 115	551 x 115
	8	10.0	19	665 x 115	646 x 115
32.5	4	10.7	45	530 x 115	495 x 115
	6	10.7	45	630 x 115	585 x 115
	8	10.7	45	720 x 135	720 x 115
35	4	11.6	45	585 x 115	540 x 115
	6	11.6	45	720 x 115	675 x 115
	8	11.6	45	765 x 135	720 x 135
37.5	4	12.4	45	630 x 115	585 x 115
	6	12.4	45	720 x 135	720 x 115
	8	12.4	45	810 x 135	765 x 135
40	4	13.2	45	675 x 115	585 x 115
	6	13.2	45	720 x 135	720 x 135
	8	13.2	45	855 x 135	810 x 135

Nothing contained in this material shall be construed as a warranty or otherwise as to the accuracy or safety of the information provided. Specific design work should be carried out by qualified engineers.

Design information for structural laminated timber is fully contained in NZS 3603 Chapter 8.



McIntosh Timber Laminates Limited

9 Bostock Place, East Tamaki. PO Box 14 604, Panmure, Auckland, New Zealand.

Telephone: 64-9-273 2888 Facsimile: 64-9-273 2880

email: sales@mcintosh.co.nz

website: www.mcintosh.co.nz

